

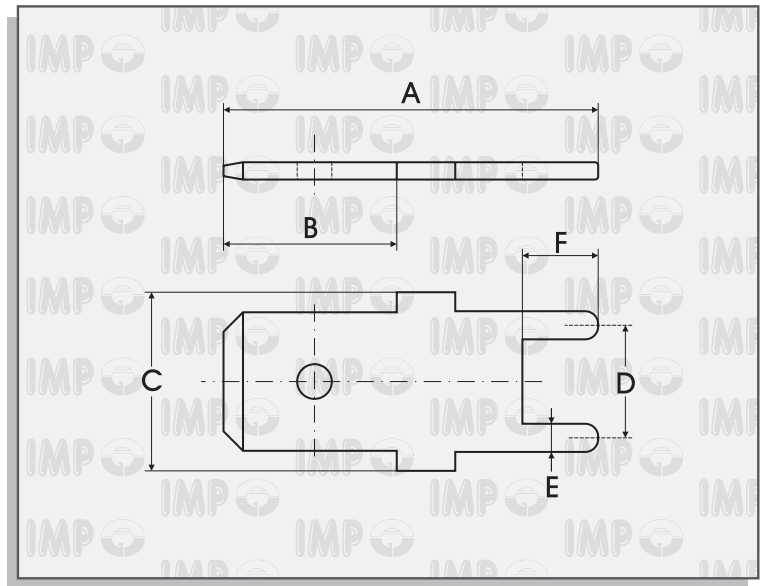

LINGUETTE PER CIRCUITO STAMPATO	6.3 mm
TABS FOR PRINTED CIRCUIT	6.3 mm
LANGUETTES POUR CIRCUIT IMPRIMÉ	6.3 mm
FLACHSTECKER FÜR GEDRUCKTE SCHALTUNG	6.3 mm



Spess.maschio Tab thick Epaisseur male Steckdicke mm	Spess.materiale Material thick Epaisseur matériel Material dicke mm	A	B	C	D	E	F	Codice - Part No. Code - Teile Nr.	Materiale Material Matériel Material
								Bag 5.000 Pcs. 	
0,80	0,80	17,3	8,0	8,3	5,2	1,3	3,5	150032.08.00	Cu Zn
								150032.08.01	Cu Zn gal Sn
								150032.08.06	Stell gal Sn

LINGUETTE 6.3 mm
PER CIRCUITO STAMPATO

TABS 6.3 mm
FOR PRINTED CIRCUIT

LANGUETTES 6.3 mm
POUR CIRCUIT IMPRIMÉ

FLACHSTECKER 6.3 mm
FÜR GEDRUCKTE SCHALTUNG

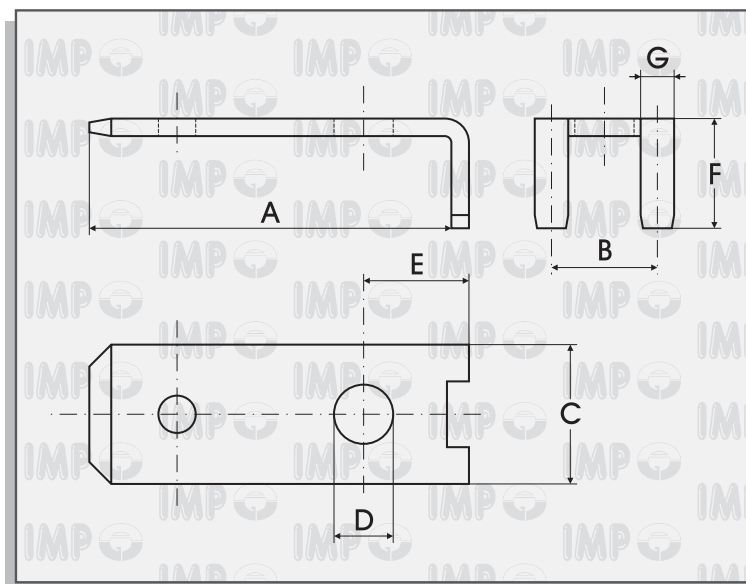

Spess.maschio Tab thick Epaisseur male Steckdicke mm	Spess.materiale Material thick Epaisseur matériel Material dicke mm	A	B	C	D	E	F	G	Codice - Part No. Code - Teile Nr.		Materiale Material Matériel Material
									Box 5.000 Pcs.		
0,80	0,80	16,5	4,8	6,3	2,7	4,8	5,0	1,5	270046.08.00		Cu Zn
									270046.08.01		Cu Zn gal Sn

LINGUETTE PER CIRCUITO STAMPATO	6.3 mm
TABS FOR PRINTED CIRCUIT	6.3 mm
LANGUETTES POUR CIRCUIT IMPRIMÉ	6.3 mm
FLACHSTECKER FÜR GEDRUCKTE SCHALTUNG	6.3 mm

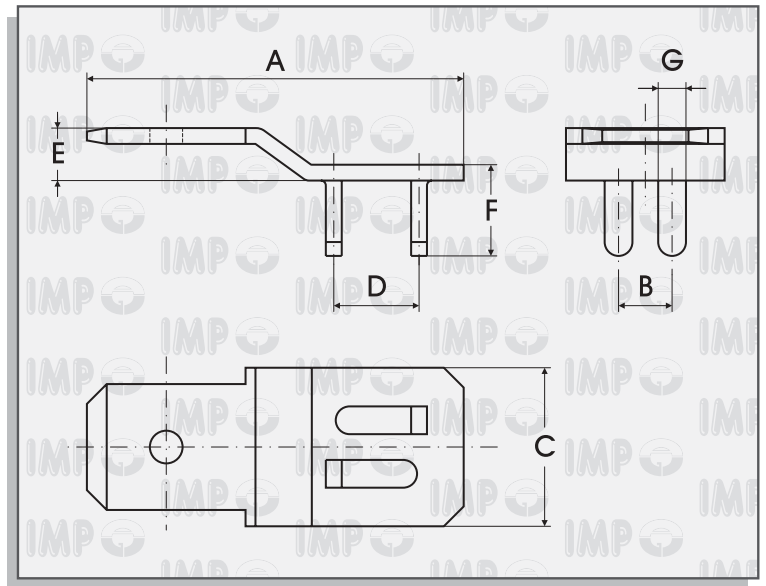

Spess.maschio Tab thick Epaisseur male Steckdicke mm	Spess.materiale Material thick Epaisseur matériel Material dicke mm	A	B	C	D	E	F	G	Codice - Part No. Code - Teile Nr.	Materiale Material Matériel Material
									Box 5.000 Pcs.	
0,80	0,80	19,0	2,7	8,0	4,3	2,6	4,6	1,4	009090.08.00	Cu Zn
									009090.08.01	Cu Zn gal Sn
									009090.08.06	Steel gal Sn