

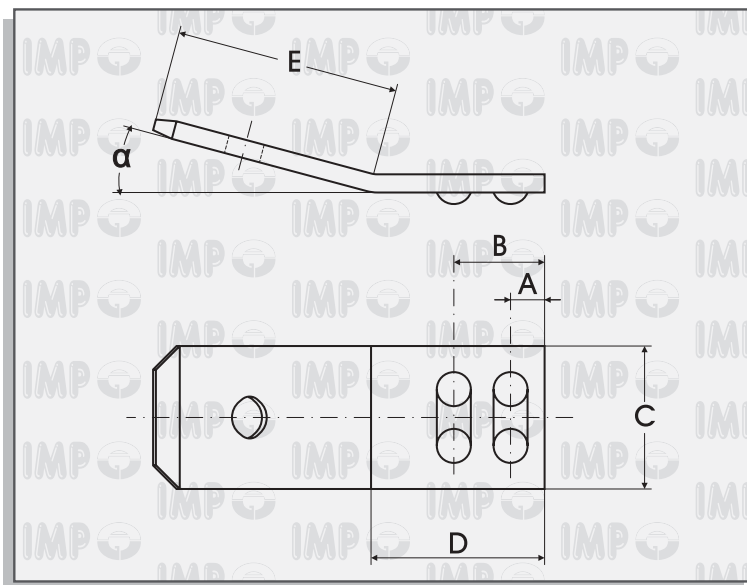

LINGUETTE PIEGATE A SILDARE	6.3 mm
BENT TABS TO WELD	6.3 mm
LANGUETTES PLOYÉES A SOUDER	6.3 mm
GEBogene FLACHSTECKER ZUM VERLÖTEN	6.3 mm



Spess.maschio Tab thick Epaisseur male Steckdicke mm	Spess.materiale Material thick Epaisseur matériel Material dicke mm	A	B	C	D	E	α	Codice - Part No. Code - Teile Nr.	Materiale Material Matériel Material
								Box  20.000 Pcs.	
0,80	0,80	1,3	3,8	6,3	6,5	10,5	15°	336.08.04	Steel gal Ni

LINGUETTE PIEGATE A SALDARE	6.3 mm
BENT TABS TO WELD	6.3 mm
LANGUETTES PLOYÉES A SOUDER	6.3 mm
GEBOGENE FLACHSTECKER ZUM VERLÖTEN	6.3 mm

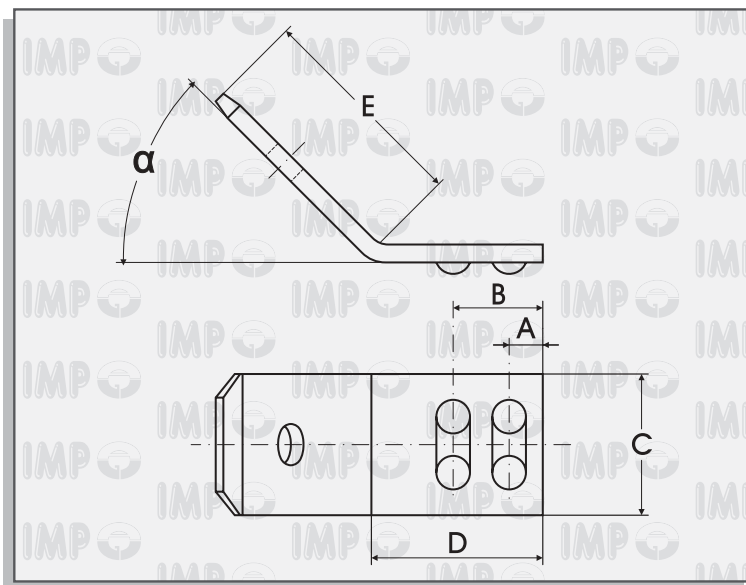

Spess.maschio Tab thick Epaisseur male Steckdicke mm	Spess.materiale Material thick Epaisseur matériel Material dicke mm	A	B	C	D	E	α	Codice - Part No. Code - Teile Nr.	Materiale Material Matériel Material
								Box 20.000 Pcs.	
0,80	0,80	1,3	3,8	6,3	7,5	9,5	45°	236.08.04	Steel gal Ni

LINGUETTE PIEGATE A SILDARE	6.3 mm
BENT TABS TO WELD	6.3 mm
LANGUETTES PLOYÉES A SOUDER	6.3 mm
GEBOGENE FLACHSTECKER ZUM VERLÖTEN	6.3 mm

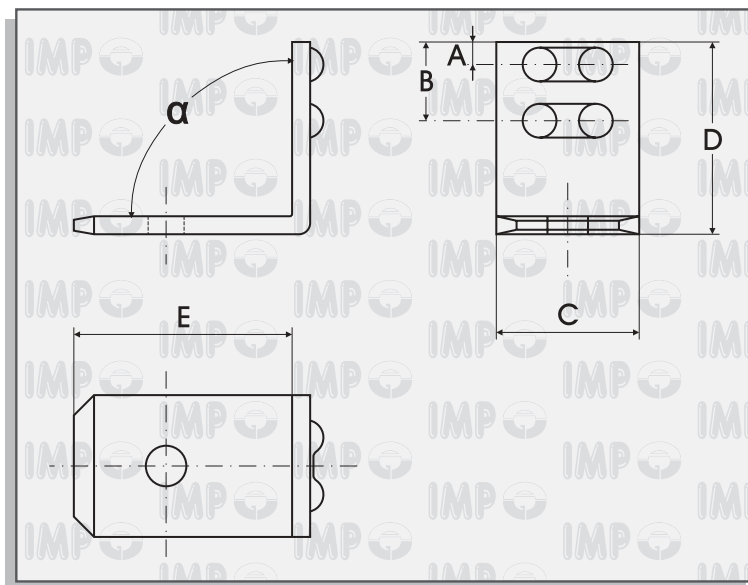

Spess.maschio Tab thick Epaisseur male Steckdicke mm	Spess.materiale Material thick Epaisseur matériel Material dicke mm	A	B	C	D	E	α	Codice - Part No. Code - Teile Nr.	Materiale Material Matériel Material
								Box  20.000 Pcs.	
0,80	0,80	1,3	3,8	6,3	8,5	9,7	90°	226.08.04	Steel gal Ni

LINGUETTE PIEGATE A SALDARE	6.3 mm
BENT TABS TO WELD	6.3 mm
LANGUETTES PLOYÉES A SOUDER	6.3 mm
GEBogene FLACHSTECKER ZUM VERLÖTEN	6.3 mm

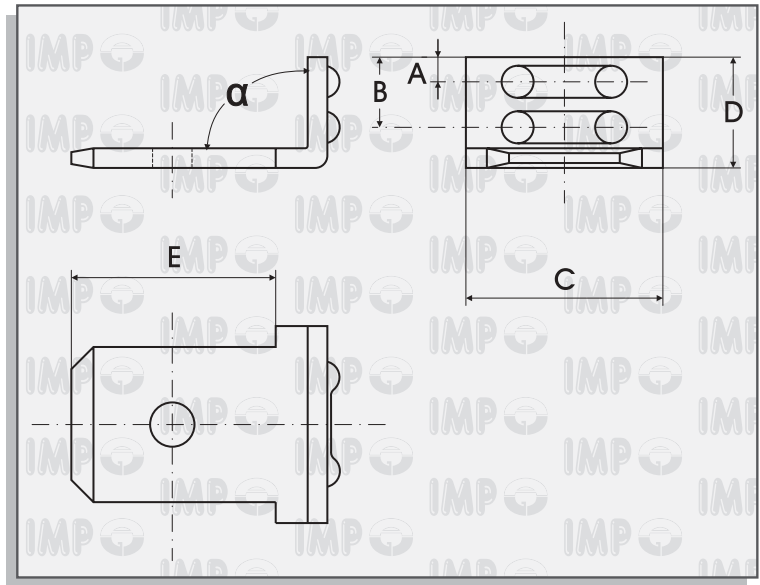

Spess.maschio Tab thick Epaisseur male Steckdicke mm	Spess.materiale Material thick Epaisseur matériel Material dicke mm	A	B	C	D	E	α	Codice - Part No. Code - Teile Nr.	Materiale Material Matériel Material
								Box 20.000 Pcs.	
0,80	0,80	1,0	2,9	8,0	4,5	8,0	90°	306.08.04	Steel gal Ni

LINGUETTE PIEGATE A SALDARE	6.3 mm
BENT TABS TO WELD	6.3 mm
LANGUETTES PLOYÉES A SOUDER	6.3 mm
GEBOGENE FLACHSTECKER ZUM VERLÖTEN	6.3 mm

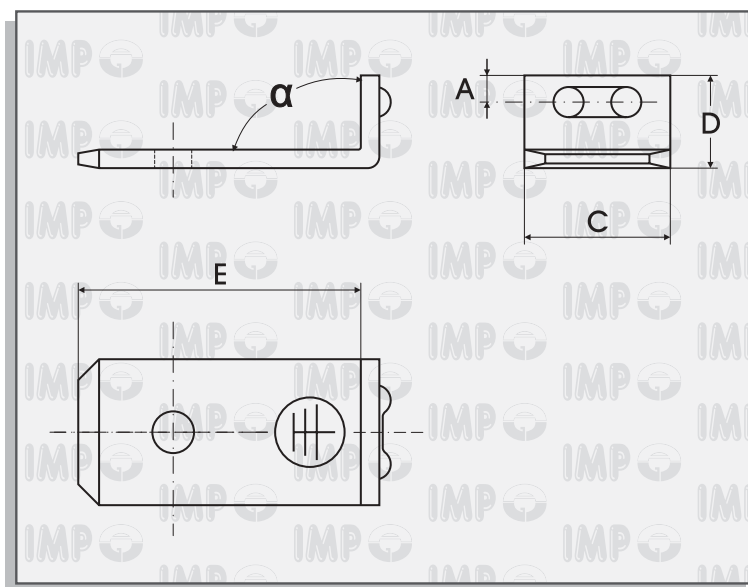

Spess.maschio Tab thick Epaisseur male Steckdicke mm	Spess.materiale Material thick Epaisseur matériel Material dicke mm	A	B	C	D	E	α	Codice - Part No. Code - Teile Nr.	Materiale Material Matériel Material
								Box  20.000 Pcs.	
0,80	0,80	1,1	-	6,3	4,0	12,2	90°	256.08.04	Steel gal Ni

LINGUETTE PIEGATE A SALDARE	6.3 mm
BENT TABS TO WELD	6.3 mm
LANGUETTES PLOYÉES A SOUDER	6.3 mm
GEBogene FLACHSTECKER ZUM VERLÖTEN	6.3 mm

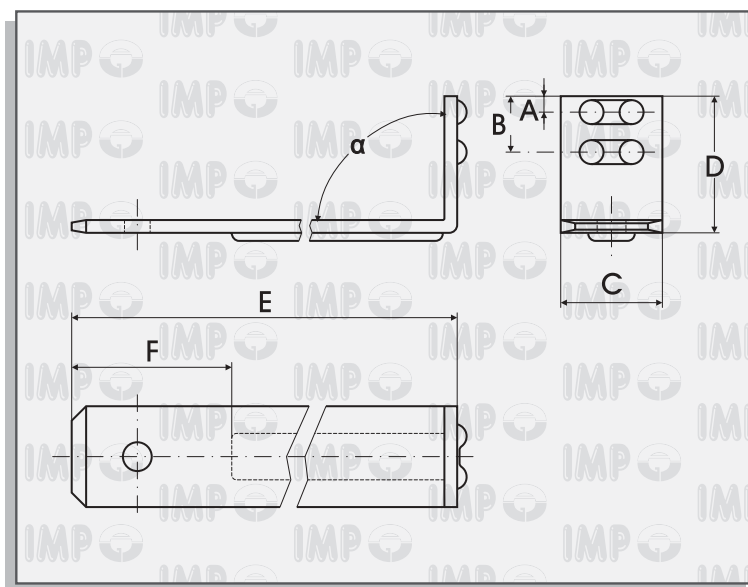

Spess.maschio Tab thick Epaisseur male Steckdicke mm	Spess.materiale Material thick Epaisseur matériel Material dicke mm	A	B	C	D	E	F	α	Codice - Part No. Code - Teile Nr.	Materiale Material Matériel Material
									Box 5.000 Pcs. 	
0,80	0,80	1,3	3,8	6,3	8,5	45,0	10,0	90°	910.08.04	Steel gal Ni

LINGUETTE PIEGATE A SILDARE	6.3 mm
BENT TABS TO WELD	6.3 mm
LANGUETTES PLOYÉES A SOUDER	6.3 mm
GEBogene FLACHSTECKER ZUM VERLÖTEN	6.3 mm

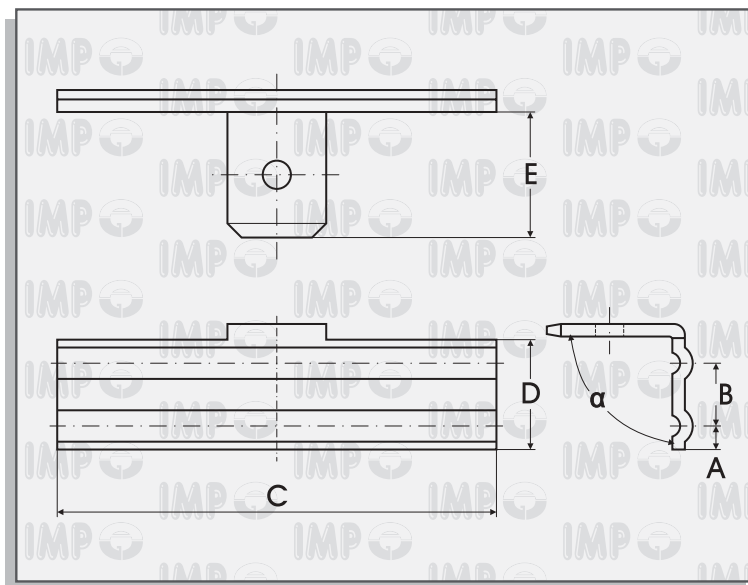

Spess.maschio Tab thick Epaisseur male Steckdicke mm	Spess.materiale Material thick Epaisseur matériel Material dicke mm	A	B	C	D	E	α	Codice - Part No. Code - Teile Nr.	Materiale Material Matériel Material
								Box 5.000 Pcs. 	
0,80	0,80	1,5	4,0	23,0	7,0	8,0	90°	176.08.04	Steel gal Ni