

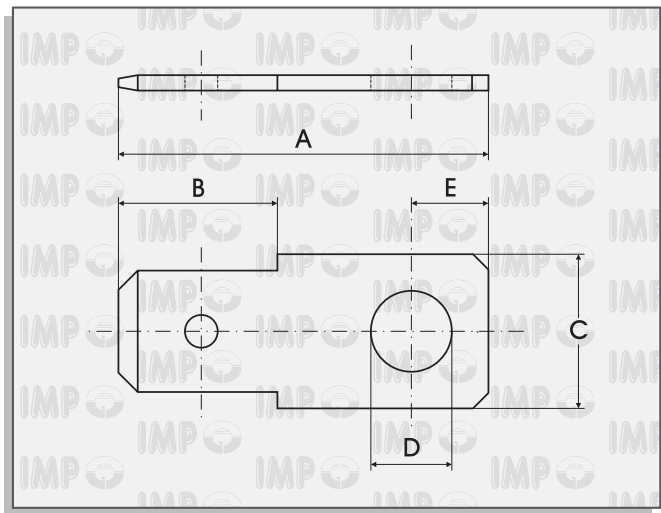



LINGUETTE	6.3 mm
TABS	6.3 mm
LANGUETTES	6.3 mm
FLACHSTECKER	6.3 mm

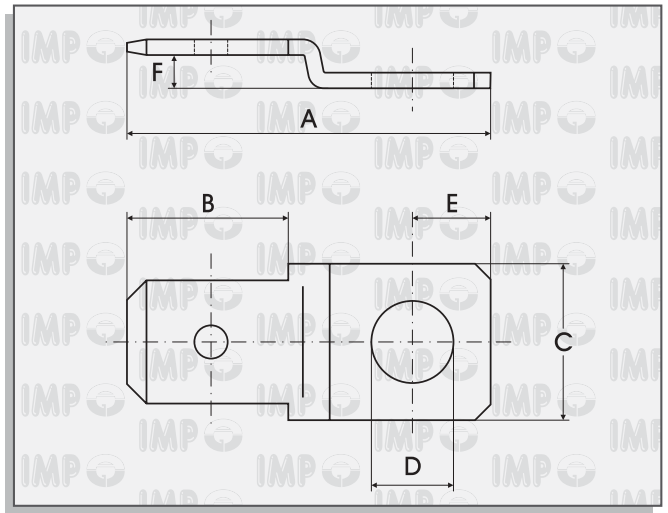

Spess.maschio Tab thick Epaisseur male Steckdicke mm	Spess.materiale Material thick Epaisseur matériel Material dicke mm	A	B	C	D	E	Codice - Part No. Code - Teile Nr.	Materiale Matériel Material
							Bag 5.000 Pcs. 	
0,80	0,80	19,2	8,0	8,0	2,7	4,0	2700.08.00	Cu Zn
							2700.08.01	Cu Zn gal Sn
0,80	0,80	19,2	8,0	8,0	3,2	4,0	3200.08.00	Cu Zn
							3200.08.01	Cu Zn gal Sn
0,80	0,80	19,2	8,0	8,0	4,2	4,0	4200.08.00	Cu Zn
							4200.08.01	Cu Zn gal Sn
0,80	0,80	19,2	8,0	8,0	5,2	4,0	5200.08.00	Cu Zn
							5200.08.01	Cu Zn gal Sn

LINGUETTE	6.3 mm
TABS	6.3 mm
LANGUETTES	6.3 mm
FLACHSTECKER	6.3 mm



Spess.maschio Tab thick Epaisseur male Steckdicke mm	Spess.materiale Material thick Epaisseur matériel Material dicke mm	A	B	C	D	E	F	Codice - Part No. Code - Teile Nr.	Materiale Matériel Material
								Bag 5.000 Pcs. 	
0,80	0,80	18,6	8,0	8,0	2,7	4,0	1,7	279090.08.00	Cu Zn
								279090.08.01	Cu Zn gal Sn
0,80	0,80	18,6	8,0	8,0	3,2	4,0	1,7	329090.08.00	Cu Zn
								329090.08.01	Cu Zn gal Sn
0,80	0,80	18,6	8,0	8,0	4,2	4,0	1,7	429090.08.00	Cu Zn
								429090.08.01	Cu Zn gal Sn
0,80	0,80	18,6	8,0	8,0	5,2	4,0	1,7	529090.08.00	Cu Zn
								529090.08.01	Cu Zn gal Sn

LINGUETTE	6.3 mm
TABS	6.3 mm
LANGUETTES	6.3 mm
FLACHSTECKER	6.3 mm

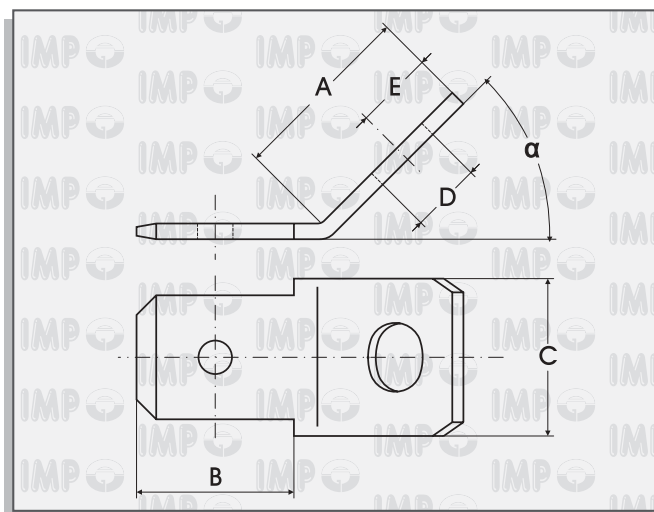

Spess.maschio Tab thick Epaisseur male Steckdicke mm	Spess.materiale Material thick Epaisseur matériel Material dicke mm	A	B	C	D	E	α	Codice - Part No. Code - Teile Nr.	Materiale Material Matériel Material
								Bag  5.000 Pcs.	
0,80	0,80	9,4	8,0	8,0	2,7	4,0	45°	2745.08.00	Cu Zn
								2745.08.01	Cu Zn gal Sn
0,80	0,80	9,4	8,0	8,0	3,2	4,0	45°	3245.08.00	Cu Zn
								3245.08.01	Cu Zn gal Sn
0,80	0,80	9,4	8,0	8,0	4,2	4,0	45°	4245.08.00	Cu Zn
								4245.08.01	Cu Zn gal Sn
0,80	0,80	9,4	8,0	8,0	5,2	4,0	45°	5245.08.00	Cu Zn
								5245.08.01	Cu Zn gal Sn

LINGUETTE	6.3 mm
TABS	6.3 mm
LANGUETTES	6.3 mm
FLACHSTECKER	6.3 mm

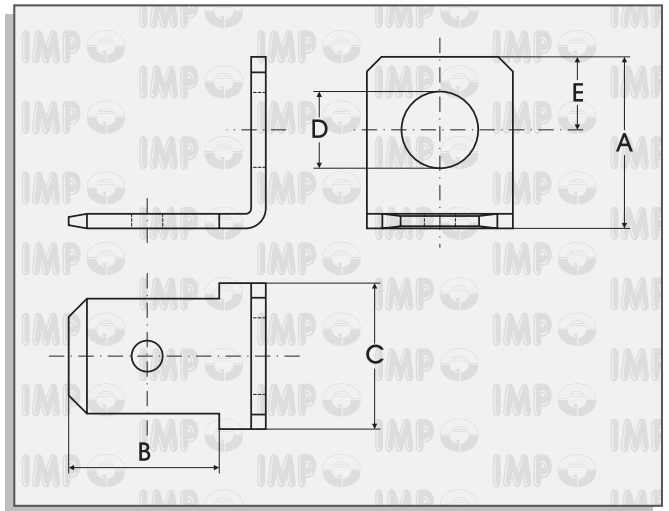

Spess.maschio Tab thick Epaisseur male Steckdicke mm	Spess.materiale Material thick Epaisseur matériel Material dicke mm	A	B	C	D	E	Codice - Part No. Code - Teile Nr.	Materiale Material Matériel Material
							Bag 5.000 Pcs. 	
0,80	0,80	9,4	8,0	8,0	2,7	4,0	2790.08.00	Cu Zn
							2790.08.01	Cu Zn gal Sn
0,80	0,80	9,4	8,0	8,0	3,2	4,0	3290.08.00	Cu Zn
							3290.08.01	Cu Zn gal Sn
0,80	0,80	9,4	8,0	8,0	4,2	4,0	4290.08.00	Cu Zn
							4290.08.01	Cu Zn gal Sn
0,80	0,80	9,4	8,0	8,0	5,2	4,0	5290.08.00	Cu Zn
							5290.08.01	Cu Zn gal Sn

LINGUETTE	6.3 mm
TABS	6.3 mm
LANGUETTES	6.3 mm
FLACHSTECKER	6.3 mm

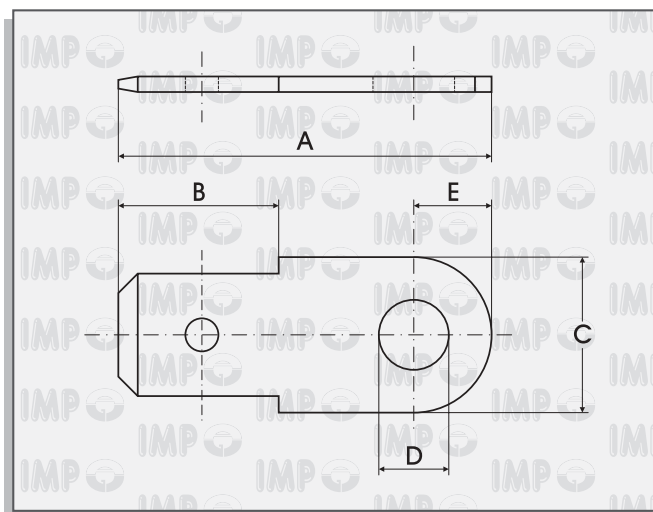

Spess.maschio Tab thick Epaisseur male Steckdicke mm	Spess.materiale Material thick Epaisseur matériel Material dicke mm	A	B	C	D	E	Codice - Part No. Code - Teile Nr.	Materiale Material Matériel Material
							Box 30.000 Pcs. 	
0,80	0,80	19,2	8,0	8,0	2,7	4,0	2700ST.08.00	Cu Zn
							2700ST.08.01	Cu Zn gal Sn
0,80	0,80	19,2	8,0	8,0	3,2	4,0	3200ST.08.00	Cu Zn
							3200ST.08.01	Cu Zn gal Sn
0,80	0,80	19,2	8,0	8,0	3,6	4,0	3600ST.08.00	Cu Zn
							3600ST.08.01	Cu Zn gal Sn
0,80	0,80	19,2	8,0	8,0	4,2	4,0	4200ST.08.00	Cu Zn
							4200ST.08.01	Cu Zn gal Sn
0,80	0,80	19,2	8,0	8,0	5,2	4,0	5200ST.08.00	Cu Zn
							5200ST.08.01	Cu Zn gal Sn